



CANOPY

FLOORING CO.



INSTALLATION GUIDE

GLUE-DOWN LUXURY VINYL TILE FLOORING

TOOLS FOR INSTALLATION

Ensure you have the following tools ready before starting

- Tape measure
- Spirit level
- Pencil
- Workbench or sawhorse
- Underlay and underlay tape (if using the self-adhesive underlay method)
- Flooring tiles or planks
- Heavy floor roller - recommended weight: at least 50 kg
- Spacers
- Utility or Stanley knife
- Handsaw or chop saw
- Chisel (for fitting around architrave)
- Drill (for areas around pipework)
- Moisture meter (suitable for your subfloor type)
- Combination square
- Beading or skirting boards (for finishing touches)
- Dryback adhesive and notched trowel (for glue-down installation)
- Safety equipment — knee pads, safety goggles, dust mask, ear defenders
- Cutting templates (optional, for awkward shapes)

INSTALLATION OPTIONS

Note: This guide covers straight plank glue-down LVT flooring. For parquet layouts, please refer to our parquet-specific installation guide.

INSTALLATION WITH DRYBACK ADHESIVE

Apply adhesive directly to the subfloor, then lay your flooring on top.

INSTALLATION WITH SELF-ADHESIVE UNDERLAY

Lay self-adhesive underlay over the subfloor, then secure your flooring to its adhesive surface.

PREPARING TO FIT YOUR FLOOR

1 CHECK THE PLANKS

Open one box to check the design and finish. Canopy's wood-effect floors feature natural variations in tone and grain — you can mix planks from different boxes for a realistic, varied look.

2 ALLOW ACCLIMATISATION

Leave your flooring in the room where it will be installed for at least 48 hours before fitting.

- Keep packs flat and horizontal.
- Distribute the weight evenly.
- Maintain a steady room temperature of 20–21°C.
- If using underfloor heating, gradually increase the temperature during acclimatisation.

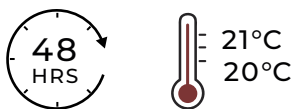

Important

Glue-down vinyl flooring is suitable for warm water underfloor heating systems only.

- The surface temperature must not exceed 27°C.
- If you're unsure of your system's temperature control, use a two-component adhesive for added stability.

Do not turn off or suddenly cool your heating system after installation. A dispersion adhesive typically takes 72 hours to cure fully, and temperature drops during this time can cause gaps or cracks.

- **If your system also provides cooling:** Ensure condensate protection is in place, so the pipe temperature stays within 3°C of the room's air temperature.

This flooring is not compatible with:

- Electric underfloor heating systems
- Floor heating systems installed before 1990

3 PREPARE THE SUBFLOOR

A good installation starts with a solid foundation.

Remove old flooring and ensure the surface is clean, dry, level, and free of debris or old adhesive.

Check the moisture level (concrete subfloors should have no more than 2% moisture content) using a moisture meter suitable for your subfloor type. For the best results, we recommend using either a concrete or wooden subfloor. Your subfloor should meet SR1 standard (no more than 3mm deviation over 2m, per BS8203). If your subfloor consists of joists, you'll need to lay a sheet of plywood on top to create a stable, even base before fitting your floor.

If your subfloor is made of joists, You'll need to fix a layer of plywood over the top, to ensure it's stable before you fit your floor.

JOIST SPACING	PLYWOOD THICKNESS
40.6cm - 48.6cm	19mm
48.7cm - 60.8cm	19-22mm
60.9cm +	22-28mm *

*Use tongue & groove (T&G) plywood or oriented strand board (OSB).

Once the plywood is in place, check again that the subfloor is level.

Next, you'll need to install a damp-proof membrane to prevent any moisture reaching the engineered boards. Secure screws or nails below the surface to avoid piercing the underlay (if using).

5 PLAN THE LAYOUT

Before you start fitting, plan how your floor will run.

Lay planks parallel to the longest wall for the best visual result. In square rooms, aligning with the main light source often looks best. Dry lay a few rows to check alignment before gluing.

5 FINAL CONSIDERATIONS

Your new floor should be one of the last steps in your renovation. Fit cabinets, islands or built-in furniture first to avoid damage. Another important tip is to work from top to bottom of your room to minimise damage.

INSTALLING YOUR FLOOR DRYBACK ADHESIVE METHOD

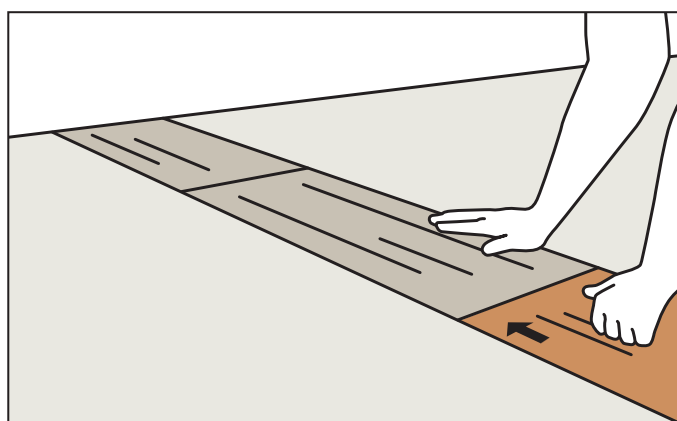
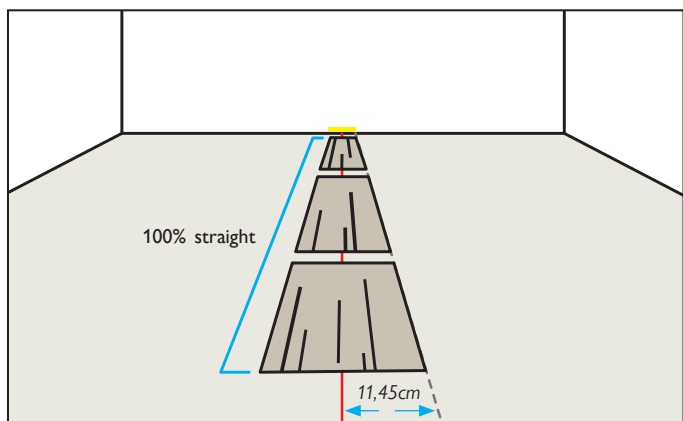

1 APPLY ADHESIVE AND SECURE PLANKS

Start at the **centre of the room**, following your layout line. Use a notched trowel to spread adhesive evenly. Only apply as much as you can cover within the adhesive's open time. Follow the manufacturer's instructions for coverage and drying times.

2 CONTINUE WITH FIRST ROW

Place planks side by side without forcing them together. Roll each section immediately using a heavy floor roller to ensure full contact. Leave a 2.5mm expansion gap around all walls, pillars and fixed features.

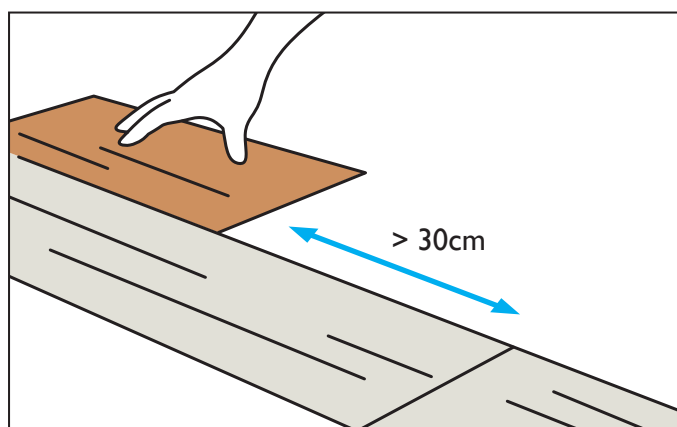
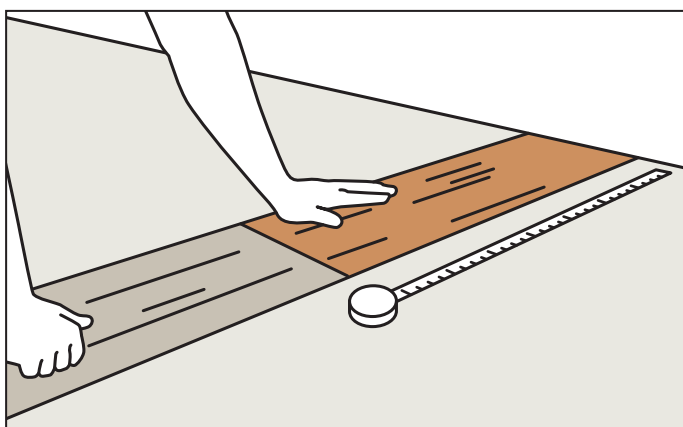

3 MEASURE AND CUT FINAL BOARD

Measure and cut final board of the first row to fit snugly against the wall.

4 STAGGER PLANKS

To avoid a 'stair-step' effect, don't start the next row with that remaining piece — you'll see repeating joints. Staggering your planks will create a more natural look. If you're installing glue-down tiles, these can be laid in a straight, half-offset or staggered pattern. Stagger plank joint seams by at least 30cm and tile joints by at least 20cm.

INSTALLING YOUR FLOOR DRYBACK ADHESIVE METHOD

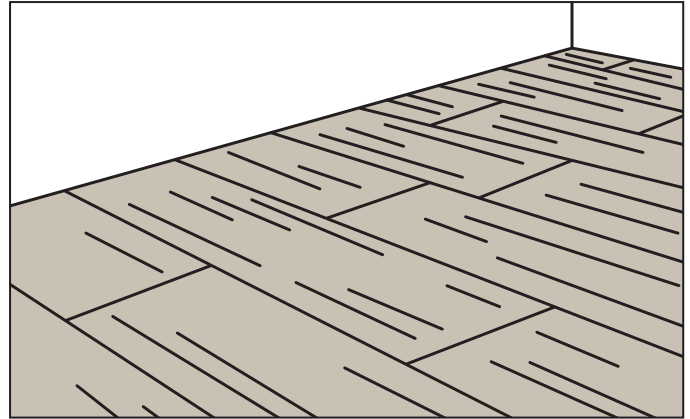
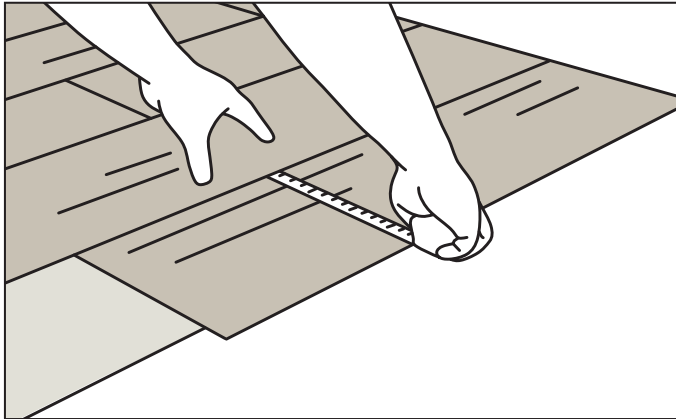

5 LAY REMAINING ROWS

Lay each new row, connecting it to the previous row carefully and without tension. Maintain your staggered seam pattern (30cm for planks, 20cm for tiles). Keep checking alignment and flatness as you go to prevent mistakes.

6 MEASURE AND TRIM BOARDS

Carefully measure the gap against the wall or around obstacles. Use a template for tricky shapes, if needed. Trim the boards so they fit snugly without pushing adjacent planks out of place. Wipe away any adhesive immediately with a damp cloth before it dries.

Note: Leave your floor for 24 hours after installation to allow adhesive to cure fully. Do not place furniture or walk on the floor during this period. If adhesive dries on the surface, soften with warm water and gently lift off with a soft brush or cloth. Never use solvents or harsh chemicals.

INSTALLING YOUR FLOOR SELF-ADHESIVE UNDERLAY METHOD

Note: Leave a 2.5 mm expansion gap around the entire perimeter. For rooms larger than 100m² or longer than 10m, increase this to 5mm.

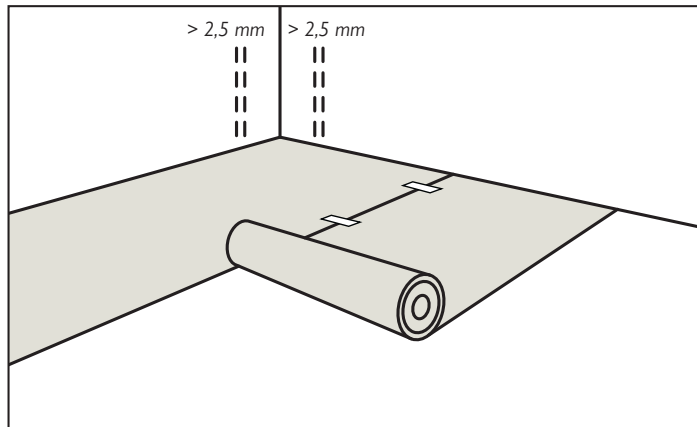

1 CUT UNDERLAY

Roll out the self-adhesive underlay with the protective film facing upward. Cut to size using a utility knife, leaving a 2.5mm gap between underlay and walls.

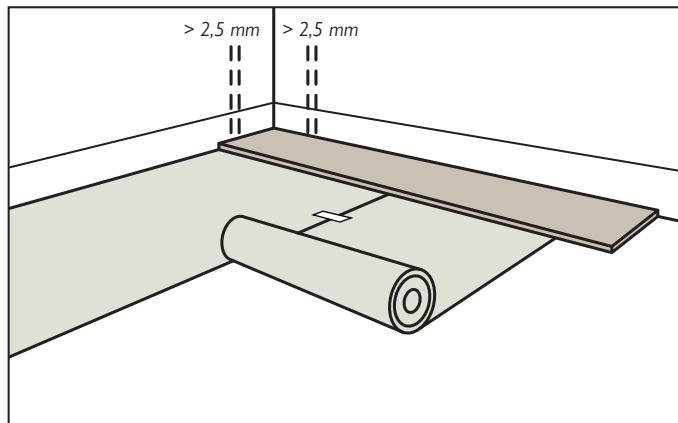

2 LAY UNDERLAY

Lay the underlay perpendicular to your flooring direction. Tape joins if needed to prevent shifting.

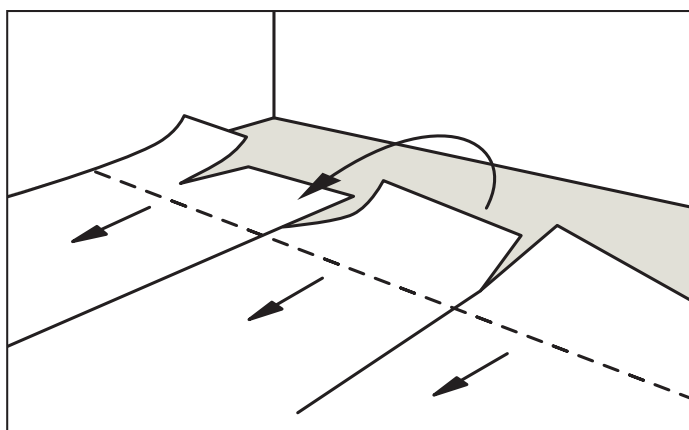

3 REMOVE FILM

Peel back only enough protective film for the first few planks — keep the rest covered to avoid dust or damage. Do not walk or kneel on the exposed adhesive layer, as this can reduce its sticking power.

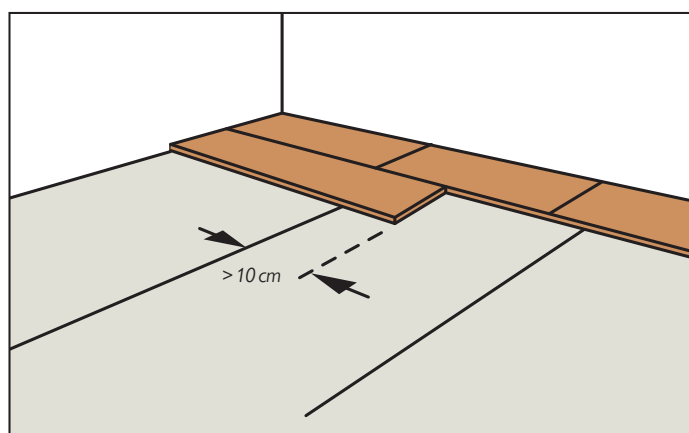

4 LAY FIRST ROW

Lay your first row of flooring straight and tight. Push each piece together neatly. Check all your planks are aligned correctly – even a small mistake could affect the overall look. You have around 10 minutes to adjust but avoid repositioning more than twice. Overlap underlay rolls by at least 10 cm for a secure bond. Continue laying and trimming planks as you go.

Note: Once your floor is finished, wait at least 30 minutes before walking on it, and 24 hours before placing furniture or rugs. Do not clean your floor until the 24-hour period is over.

FINISHING TOUCHES

FITTING AROUND PIPES

Mark the pipe position on your plank. Drill a hole and make two angled cuts to form a small wedge. Fit the board around the pipe and glue the wedge behind for a seamless look.

FITTING AROUND DOOR FRAMES

Remove the door from its hinges. Use a flooring offcut and threshold bar to mark the height for trimming the architrave. Trim with a handsaw and chisel so your flooring slides neatly underneath. Refit the door and finish edges with matching beading or skirting.

COVERING EXPANSION GAPS

Use matching beading and thresholds to cover expansion gaps and seamlessly blend the new floor with existing walls.

SPARE PLANKS FOR REPAIRS

Keep spare planks for future repairs or adjustments.

ADDRESSING LARGE EXPANSION GAPS

If the expansion gap is too large and the skirting or moulding doesn't cover it, cut strips from spare floorboards using a handsaw. Glue these strips into place to cover the gap.

DON'T FORGET YOUR FLOORING ACCESSORIES



Underlay



Adhesive



Joint tape



Stair nosing



Beading



Thresholds



Pipe covers



Skirting