



CANOPY

FLOORING CO.



INSTALLATION GUIDE

GLUE-DOWN LUXURY VINYL TILE
HERRINGBONE FLOORING

TOOLS FOR INSTALLATION

Ensure you have the following tools ready before starting:

- Tape measure
- Spirit level
- Pencil
- Marker pen (if installing with self-adhesive underlay)
- Chalk (if installing with adhesive)
- Tape (for securing tiles as you work)
- Workbench or sawhorse
- Underlay and underlay tape (if installing with self-adhesive underlay)
- Flooring tiles
- Heavy floor roller - we recommend it weighs at least 50kg
- Spacers
- Stanley knife
- Handsaw or chop saw
- Chisel (for fitting around architrave)
- Drill (for covering pipework)
- Moisture meter – the correct type for your subfloor
- Combination square
- Beading or skirting boards (to finish the look)
- Dryback adhesive and notched trowel (if using gluing installation method)
- Safety equipment i.e. knee pads, safety goggles, dust masks, ear defenders
- Cutting templates for awkward shapes (optional)

INSTALLATION OPTIONS

Note: Installing parquet flooring can be intricate, requiring precise measurements. If you feel uncertain, we advise hiring a professional fitter for the job.

INSTALLATION WITH ADHESIVE

Apply adhesive directly to the subfloor, then lay your flooring on top.

INSTALLATION WITH SELF-ADHESIVE UNDERLAY

Lay self-adhesive underlay over the subfloor, then secure your flooring to its adhesive surface.

PREPARING TO FIT YOUR FLOOR

1 CHECK THE PLANKS

Open one box and check the design, pattern, and quality of your flooring. Canopy's wood-effect LVT features natural colour variations for a realistic finish. Mix planks from different boxes to achieve a beautiful, natural look.

2 ALLOW ACCLIMATISATION

Allow your flooring to rest in the room where it will be fitted for at least **48 hours**. Keep packs flat and horizontal with even weight distribution. Maintain a steady temperature between **18-27°C**.

If you're using **underfloor heating**, gradually increase the temperature during acclimatisation to avoid shock to the material.

Important

Glue-down vinyl flooring is suitable for warm water underfloor heating systems only.

- The surface temperature must not exceed 27°C.
- If you're unsure of your system's temperature control, use a two-component adhesive for added stability.

Do not turn off or suddenly cool your heating system after installation. A dispersion adhesive typically takes 72 hours to cure fully, and temperature drops during this time can cause gaps or cracks.

- **If your system also provides cooling:** Ensure condensate protection is in place, so the pipe temperature stays within 3°C of the room's air temperature.

This flooring is not compatible with:

- Electric underfloor heating systems
- Floor heating systems installed before 1990

3 PREPARE THE SUBFLOOR

A good installation starts with a solid foundation.

Remove old flooring and ensure the surface is clean, dry, level, and free of debris or old adhesive. Check the moisture level (concrete subfloors should have no more than 2% moisture content) using a moisture meter suitable for your subfloor type. For the best results, we recommend using either a concrete or wooden subfloor. Your subfloor should meet SR1 standard (no more than 3 mm deviation over 2 m, per BS8203).

If your subfloor consists of joists, you'll need to lay a sheet of plywood on top to create a stable, even base before fitting your floor.

Use plywood or OSB based on joist spacing:

For joist floors:

JOIST SPACING	PLYWOOD THICKNESS
40.6cm - 48.6cm	19mm
48.7cm - 60.8cm	19-22mm
60.9cm +	22-28mm *

*Use tongue & groove (T&G) plywood or oriented strand board (OSB).

Once the plywood is in place, check again that the subfloor is level.

Next, you'll need to install a damp-proof membrane to prevent any moisture reaching the engineered boards. Secure screws or nails below the surface to avoid piercing the underlay (if using). Vacuum thoroughly.

4 PLAN THE LAYOUT

Before you start installing the floor, look through the boards you have looking for natural grains, knots and shades deviations. You can then use these boards as focal points, mixing the planks to achieve the desired effect you're looking for. If you come across some planks you're not happy with, keep them for cutting or use them in hidden spots on your floor. Think about how you want your parquet floor to look. Choose the direction and style of the pattern and how you want the eye to be drawn when you enter the room.

Final Considerations

Your new floor should be one of the last steps in your renovation. Fit cabinets, islands or built-in furniture first to avoid damage. Another important tip is to work from top to bottom of your room to minimise damage.

INSTALLING YOUR FLOOR DRYBACK ADHESIVE METHOD

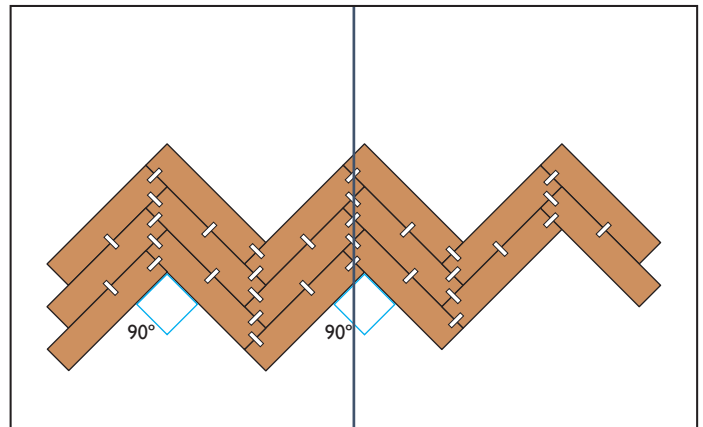
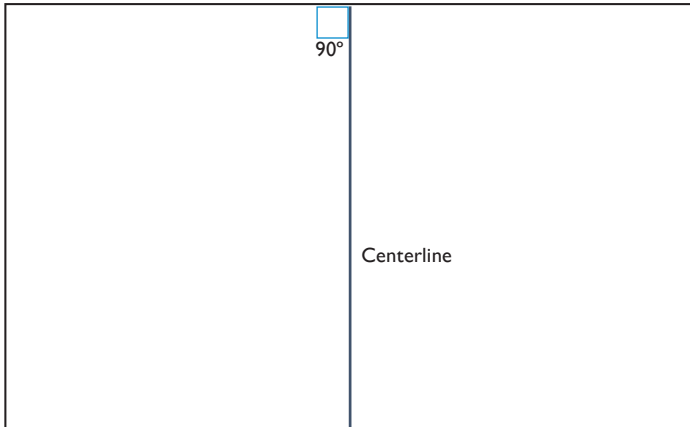

1 MARK CENTRE LINE

Measure the width of the room from your starting wall and mark a centre line using chalk. This line acts as your main guide for the herringbone pattern.

2 LAY OUT STARTING ROWS

Dry lay two or three rows of tiles in the herringbone pattern, ensuring each corner forms a perfect 90° angle. Use tape to hold them in place.

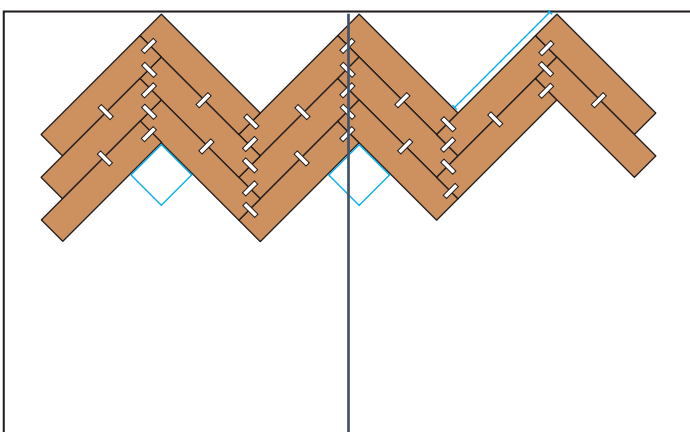

3 CHECK ALIGNMENT

Place the assembled section along your starting wall, aligning the points with your centre line. Check that the distance from the starting wall is even across the room and your corners remain at 90°.

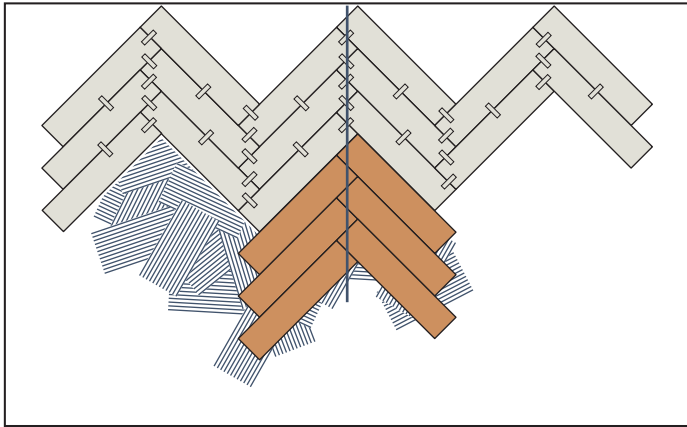

4 APPLY ADHESIVE, LAY AND ROLL

Prepare the adhesive according to the manufacturer's instructions. Using a notched trowel, spread adhesive evenly across a section wide enough for two or three strips. Only apply an amount that can be covered within the adhesive's open time.

Gently place your pre-assembled strips into the adhesive and roll over them immediately with a heavy floor roller to ensure full contact.

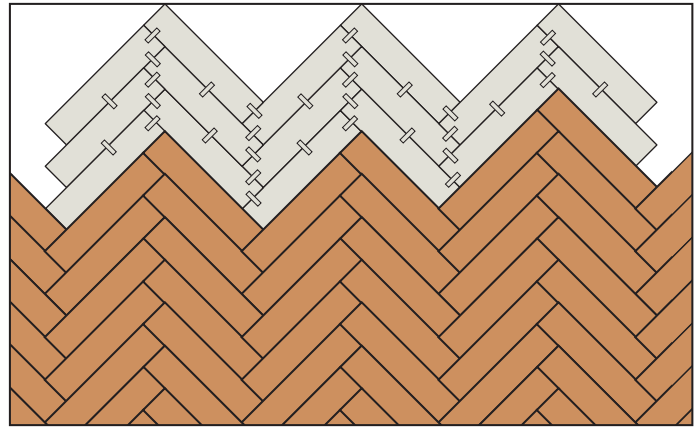

5 CONTINUE LAYING

Work outwards from your starting point, checking alignment regularly. Keep all angles exactly 90° the whole way through.



6 FINISH UP

Once your layout is holding steady, remove the taped-together strips and continue fitting the rest of the floor tightly against your starting wall until your beautiful herringbone floor is complete!

Leave your floor for 24 hours after installation to allow adhesive to cure fully. Do not place furniture or walk on the floor during this period.

If adhesive dries on the surface, soften with warm water and gently lift off with a soft brush or cloth. Never use solvents or harsh chemicals.

Note: If your room is no bigger than 100m² or extends no more than 10m in length, leave a 2.5mm expansion gap between the underlay/flooring and the walls around the perimeter of the room.

If your room is more than 100m² or extends more than 10m in length, you'll need to increase these gaps to 5mm.

INSTALLING YOUR FLOOR SELF-ADHESIVE UNDERLAY METHOD

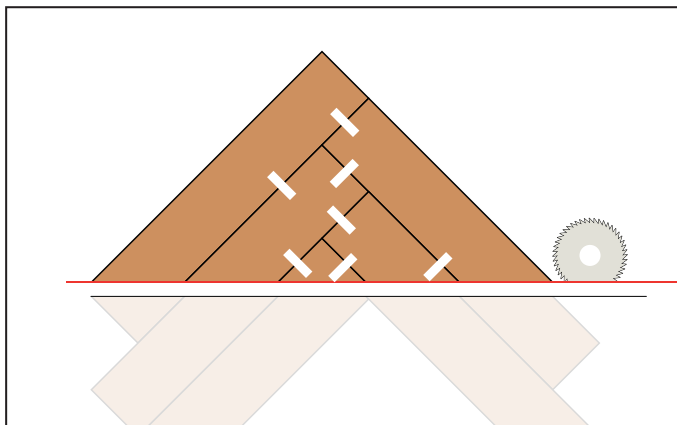
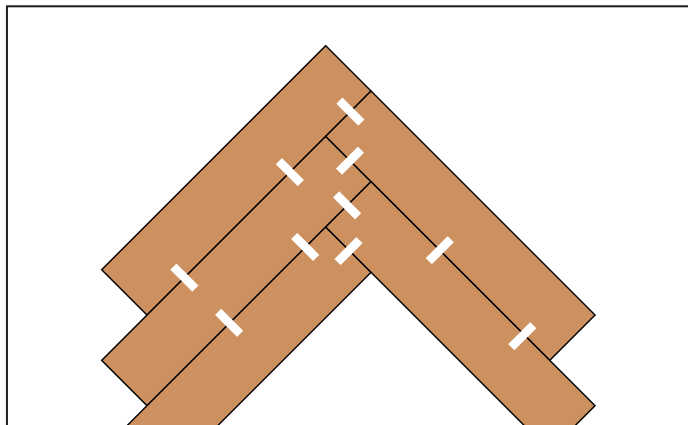

1 ALIGN TILES

Begin by aligning your tiles, as shown in the image, making sure there are no gaps or overlaps between pieces. Secure them tightly together with tape so they stay in place. Remember, herringbone flooring relies on accuracy. Even the tiniest gap will repeat and grow as you continue laying the floor, so check every join carefully.

2 CREATE STARTER TRIANGLE

Cut along the red guide line (shown in the image above) to create your starter triangle. Keep the remaining tiles below the cut, as you'll use these for the final row later on. Every starter triangle should be the same — three tiles on the left and two on the right. Don't stray from this pattern or you'll run into problems later!

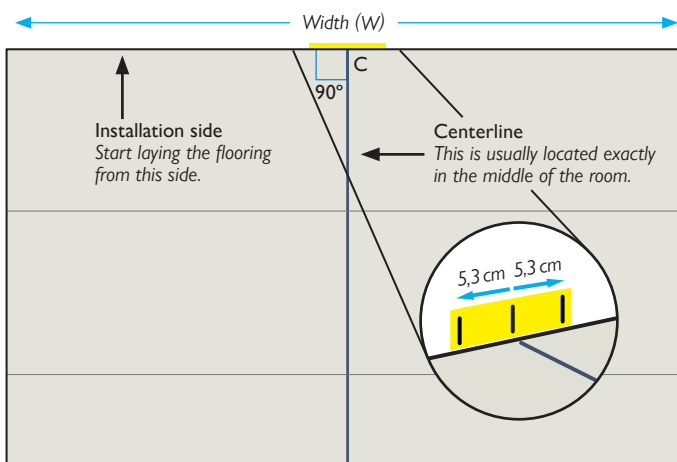
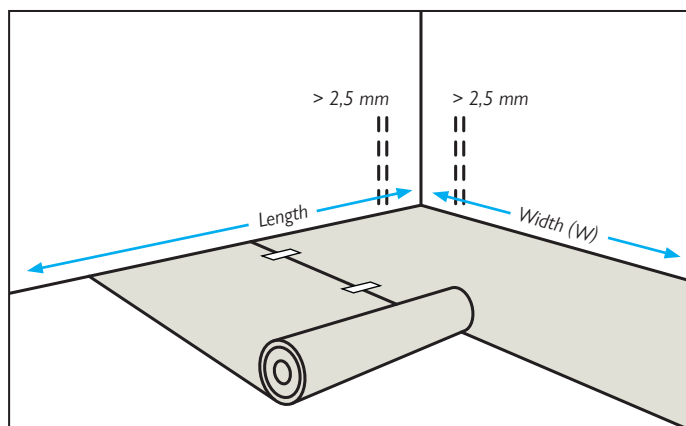

3 CUT UNDERLAY TO SIZE.

Cut your self-adhesive underlay to size using a utility knife. Lay it across the width of the room with the protective film facing upward. Leave an expansion gap between the underlay and the wall (see the note on expansion gaps in the box above), then tape the joins (using underlay tape) to stop the strips from moving while you work.

4 MARK YOUR CENTRE LINE AND REFERENCE POINTS

Use a marker to draw a centre line across the protective film, aligning with the centre of the room. Add a reference point (C) on the wall to help you remember where the centre line is. Note, this is not the same as the 'installation line' in Step 7.

Add two more marks, each 5.3cm away from your centre line, one on the left and one on the right. These will help you position your first triangle perfectly.

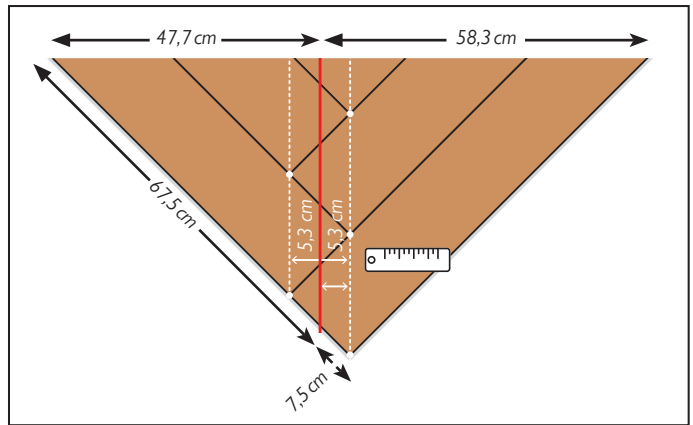
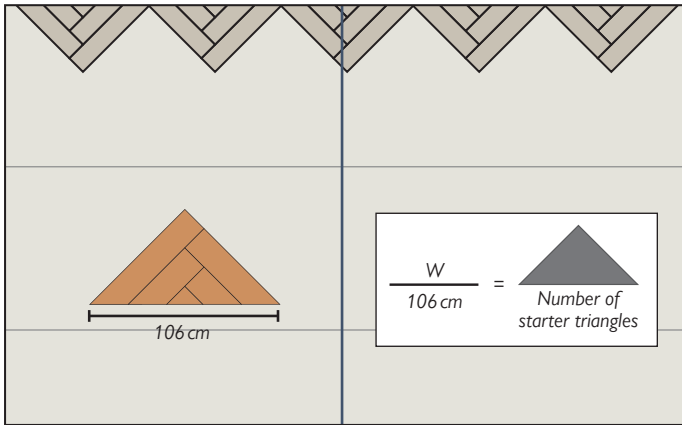

5 MEASURE AND DIVIDE

To find out how many triangles you'll need, take the full width of your installation area and divide it by 106cm, which is the longest side of the triangle.

6 POSITION FIRST TRIANGLE

Identify the installation line on your first triangle (shown in the image above). This is the centre of the herringbone pattern (not the very tip). Position the first triangle so its installation line aligns exactly with the centreline of your room, using your 'centre line' marker as a guide.

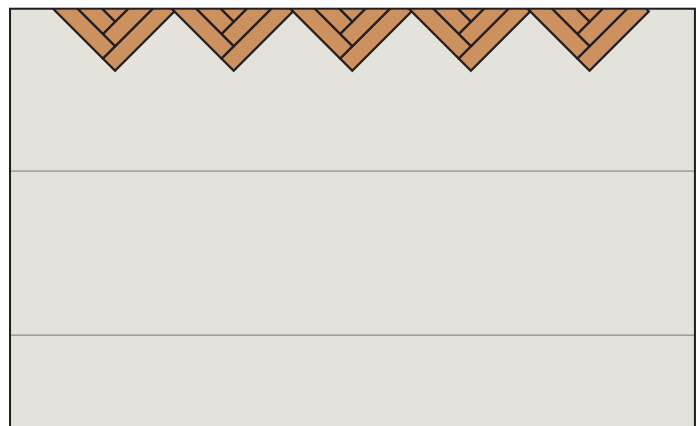
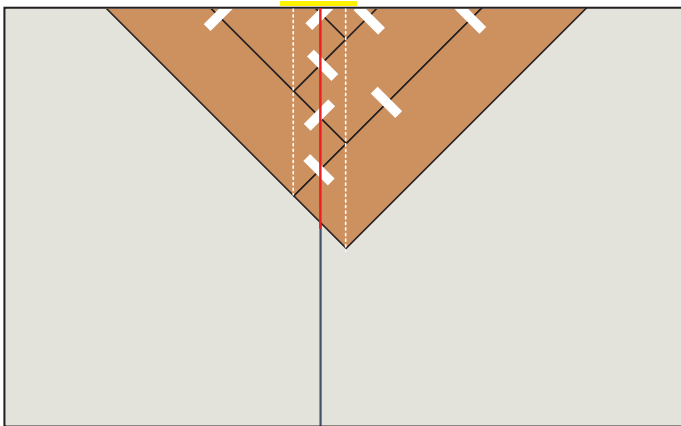

7 STICK AND SECURE

Make a small cut in the underlay film and peel back a small section along the centre line (just enough to place your first triangle). Carefully press the first triangle into place. Continue laying additional triangles to the left and right, making sure the installation line and centre line are aligned.

8 SECURE LEFT & RIGHT TRIANGLES

Repeat the same process for the triangles on the left and right sides, keeping everything perfectly aligned. Replace the protective film over exposed areas to protect the adhesive from dust. Don't walk or kneel on any uncovered adhesive — this can affect its grip and the final finish.

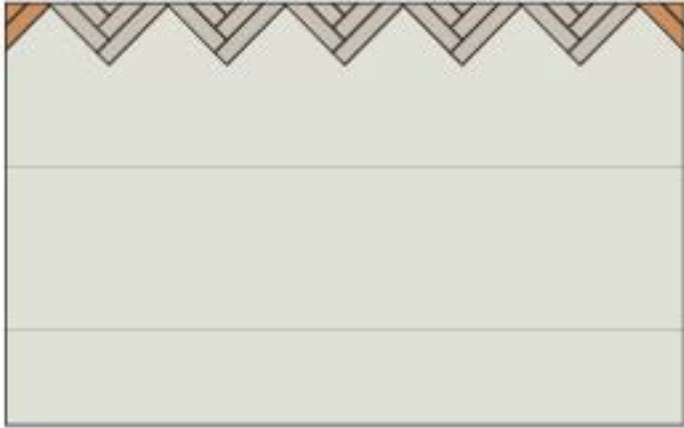

8 CONTINUE LAYING FLOOR

Continue filling in both sides of the centreline, trimming the last triangles neatly to fit using a utility knife. Once the first section is secure, pull the film back a little further and start laying the tiles one strip at a time. Keep each piece tight and straight — even a small misalignment here could affect the overall result.

Keep the centreline visible as you go and check that your layout remains straight across the room. You can adjust tiles within 10 minutes if needed, but try not to reposition them more than twice to avoid weakening the adhesive.

Leave your floor for 24 hours after installation to allow adhesive to cure fully. Do not place furniture or walk on the floor during this period.

If adhesive dries on the surface, soften with warm water and gently lift off with a soft brush or cloth. Never use solvents or harsh chemicals.

FINISHING TOUCHES

FITTING AROUND PIPES

Mark the pipe position on your plank. Drill a hole and make two angled cuts to form a small wedge. Fit the board around the pipe and glue the wedge behind for a seamless look.

FITTING AROUND DOOR FRAMES

Remove the door from its hinges. Use a flooring offcut and threshold bar to mark the height for trimming the architrave. Trim with a handsaw and chisel so your flooring slides neatly underneath. Refit the door and finish edges with matching beading or skirting.

COVERING EXPANSION GAPS

Use matching beading and thresholds to cover expansion gaps and seamlessly blend the new floor with existing walls.

SPARE PLANKS FOR REPAIRS

Keep spare planks for future repairs or adjustments.

ADDRESSING LARGE EXPANSION GAPS

If the expansion gap is too large and the skirting or moulding doesn't cover it, cut strips from spare floorboards using a handsaw. Glue these strips into place to cover the gap.

DON'T FORGET YOUR FLOORING ACCESSORIES



Underlay



Adhesive



Joint tape



Stair nosing



Beading



Thresholds



Pipe covers



Skirting